

**A
PROJECT REPORT**

ON

“Hotel Management System”

FOR



Arts, Commerce & Science College, Sonai



SUBMITTED TO SAVITRIBAI PHULE PUNE UNIVERSITY, PUNE

BY

Miss. Gaikwad Kaveri Ashok

Miss. Tathe Akshada Chandrakant

Under the Guidance of

Shri. Bahirat Sir

**IN PARTIAL FULLFILLMENT OF BACHELOR OF COMPUTER
APPLICATIONS**

FOR THE ACADEMIC YEAR

2020-2021



Mula Education Society's
ARTS, COMMERCE & SCIENCE COLLEGE SONAI

Tal. Newasa, Dist. Ahmednagar - 414105. Ph./Fax : (02427) 231384
E-mail : sonaicollege@yahoo.co.in Website - www.acssonaicollege.com

Affiliated to Savitribai Phule Pune University (I.D.PU/AN/ASC/031/1989)
NAAC REACCREDITED 'A' GRADE and ISO 9001 : 2008 CERTIFIED

CERTIFICATE

This is to certify that **Miss. Gaikwad Kaveri Ashok & Miss. Tathe Akshada Chandrakant** rebonafide students of **Arts, Commerce and Science College, Sonai** have successfully completed the Mini project work as prescribed by the Savitribai Phule Pune University, Pune in the partial fulfillment of the requirement of Third Year, Bachelor of Business Administration (Computer Application) Program for the academic year **2020-2021**.

The Project Work titled as “**Hotel Management System**”

Shri. Bahirat Sir

Project Guide

Shri. Darandale .S.R

H.O.D.

External Examiner

Internal Examiner

ACKNOWLEDGEMENT

A successful project is the result of teamwork and co-ordination that includes not only the group of developers who put forth the ideas, logic and efforts but also who guide them. So, at the completion of the project, I feel obliged to extend my gratitude towards all those who made valuable contributions throughout my training period.

I wish to convey deep sense of gratitude towards Mr. Bahirat Sir , for all the cooperation and help at the time I needed.

I would like to express my sincere thanks to Mr. Bahirat Sir (Project Guide) whose keen interest coupled with valuable suggestions helped me in completion

of my project report

 **Miss. Gaikwad Kaveri Ashok**

 **Miss. Tathe Akshada Chandrakant**

DECLARATION

We hereby declare that the project work entitled, “ **Hotel Management System**” submitted under the guidance of Shri. Bahirat Sir is our original work completed under the four walls of our institute.

The Report submitted is our own work and has not been duplicated from any other source. We shall be responsible for any unpleased moment/situation.

 Miss. Gaikwad Kaveri Ashok

 Miss. Tathe Akshada Chandrakant

INDEX

| Sr.No. | Topic Name | Page No. |
|---------------|--------------------------|-----------------|
| 1 | Introduction | |
| 2. | Existing System | |
| 3. | Proposed Solution | |
| 4. | Scope | |
| 5. | Objective | |
| 6. | Hardware and Software | |
| 7. | System Analysis | |
| 8. | File Database Design | |
| 9. | Screen Layout and Design | |
| 10. | Future Enhancement | |
| 11. | Conclusion | |
| 12. | Limitations | |
| 13. | Reference | |

Introduction

It is being a result of patience, hard work & mutual understanding; it is our great pleasure to represent this project on **“Hotel Management System”**.

Everyone needs some where to fallback upon sometimes. And we are not an exception. The completion of this project is the result of immense, heartfelt advice and suggestions, from various people in various fields no matter how small they might seem to be.

This project helps to reduce paper work,time ,cost etc.

Many things helps us to bring the right information required for project completion

This project helps to reduce various problems regarding hotel. Helps to manage food ,customer ,bill etc details

accurately.

EXISTING SYSTEM AND IT'S LIMITATIONS

Now, if we take an overview of manual account system for Hotel Management System then we will see that there is lots of heavy work for accountant to do just like finding information about Customer ,Food and Bill etc.

In this, lots of time was wasted. In this there are chances of making mistakes while collecting information or some time an information may not found. So this is the main drawback of manual account system.

Also it take lots of time to make a paper work. It has drawback that information is less durable. If any disaster happens there is chances to loss the records.

- The existing system doing all process manually.
- The personnel should refer all the records kept for years ago to simply know details .this is so tedious and time consuming.
- This existing system is difficult when number of users increasing.

Need For System:

- Accurate processing of information
When data is handled manually there are more chances of mistakes in calculations. So we need to design such electronic system.
- Genuine processing of information
In manual handling of data there are also chances of intentional manipulation of entry values.
- Keeping track of old data efficiently
For effectively and faster accessing record of a particular instance we need such electronic system.
- Storage of information
To store the old records of distributor and their details, we need storage of information. Effective Backup in such case is possible with the help of computerized system only.

SCOPE OF THE PRAPOSED SYSTEM

The Scope study is useful to evaluate the cost and benefits of the system requested .the feasibility study try to anticipate future condition of software development .there are few major aspects in scope study like technical scope and economical scope.Major advantages of proposed system over manual system are:

1. Time sharing
2. Rapid information processing
3. Accurate report generation
4. Less paper work
5. Fast & reliable information distribution
6. Reduction in cost

OBJECTIVES

- This System will help Hotel, owner, and as well as Customers.
- To reduce paper work and human efforts.
- It is designed such a way that owner can view all the updates of the Hotel Details.
- The software will help in easy maintaining and updating Food details.
- Also quick and easy comparison of different foods for the customers.

REQUIRMENTS

Software and Hardware are the two sides of one coin i.e software without hardware is of no use and hardware software is also useless.so our system requirement are divided into hardware and software requirement .

Hardware Requirements:-

| | |
|-----------|---------------------------------|
| RAM | - 2GB. |
| Hard Disk | - 320GB |
| Mouse | - Microsoft compatible. |
| Printer | - Laser |
| Keyboard | - Standard 101/102-key keyboard |

Software Requirements:-

| | |
|------------------|-------------------------------|
| Operating System | - Windows XP/ WINDOWS 7/8/10. |
| Back End Tool | - MS ACCESS |
| Front End Tool | - VB 6.0. |

System Analysis

2.1 Fact Finding Techniques:

To study the system we need to collect facts i.e. gathering information about the system. The proper use of tools for gathering information is the key to success analysis.

Various fact finding techniques are:-

- Interview.
- Record Review.
- Questionnaire
- Observation.

Analyst implements any one of these techniques to develop a system which is accurate & comprehensive.

We used the following Fact Finding Technique:

- Questionnaire
- Observation

Questionnaire:-

A questionnaire is a perform a containing a sequence of questions to collect information from a user. The questions are clear & simple & to the point. The success of collecting data through a questionnaire mainly depends on how skillfully & imaginatively the questionnaire has been designed.

For collecting the information about the System we have visited some

shops and asked about their systems by asking some questions.

Observation:-

Observation allows analyst to gain information they can't from any other fact-finding techniques. In this method analyst observes the flow of documents, way the process is carried out etc.

Because of lack of record review fact finding technique we visited Shops and observed their flow of document process.

Feasibility Study:

Feasibility is the determination of whether or not a project is within the scope of organization. Feasibility is carried out to select the best system that meets performance requirements. This type of study determines if a project can and should be taken.

There are 3 types of feasibility:-

❖ Technical Feasibility:-

It is the study of hardware & software i.e. technical requirements of the system in order to inform the management & end user about the requirements of technical resources.

The system is technically feasible. No additional software or hardware is required for the implementation, as the system is developed using 'Java JDK 1.6' Technology as front-end tool & 'MS Access' as back-end tool.

❖ Economical Feasibility:-

It is the most frequently used technique for evaluating the effectiveness of the proposed system. More commonly known as cost/benefit analysis. It determines the benefits & savings that are expected from the proposed system & compare them with costs.

The system is economically feasible since it would not entail additional hardware, thereby savings on the costs & the manpower involved.

❖ Operational Feasibility:-

It is mainly related with the human factor. It checks the operating environment of the proposed system. Since the proposed system is computerized, it is finding that the system is very easy to use.

The system is window based with appropriate entry & error messages, for every screen & hence the systems very user friendly. This user friendliness of the system results in simplicity in operations of the system. The retrieval of the information will be easier as all information is stored in the database.

SYSTEM DESIGN

ERD

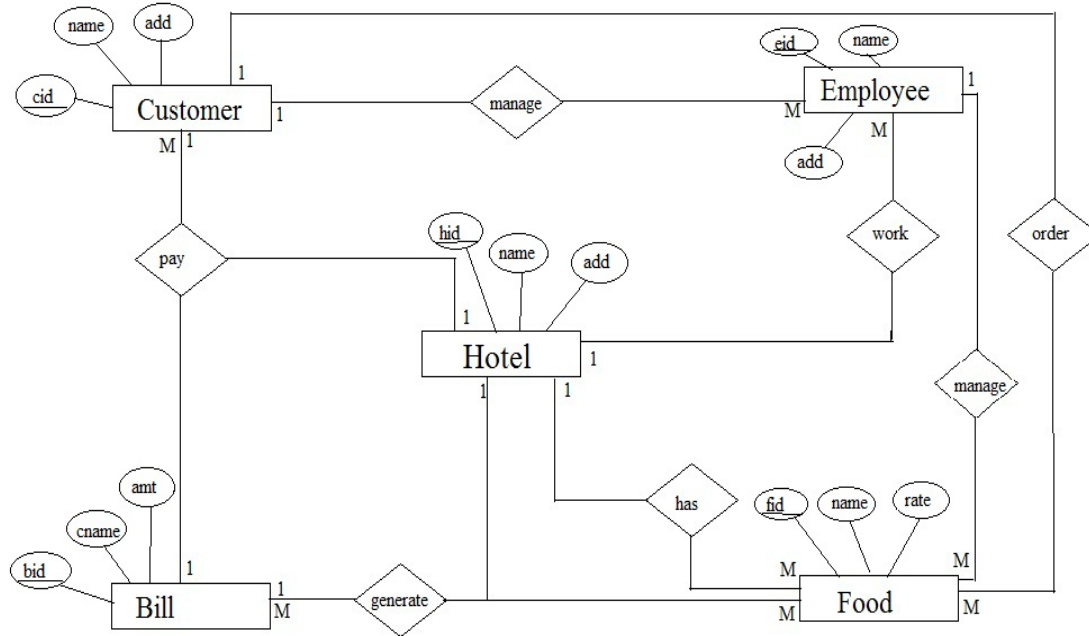

Data Flow Diagram

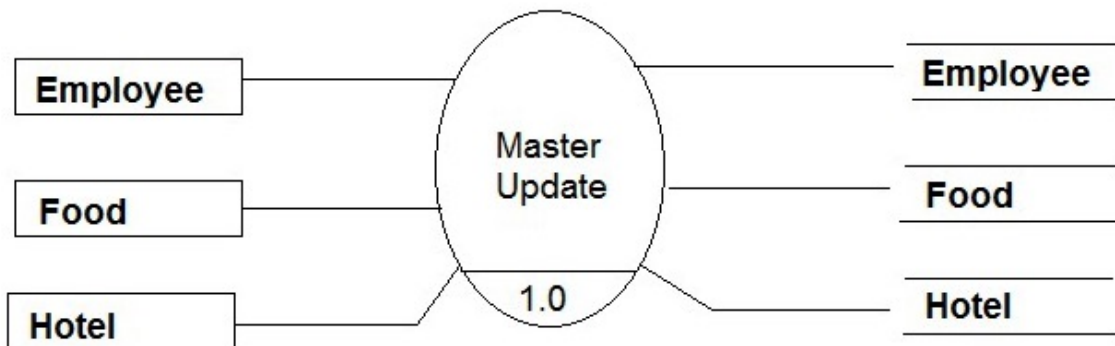
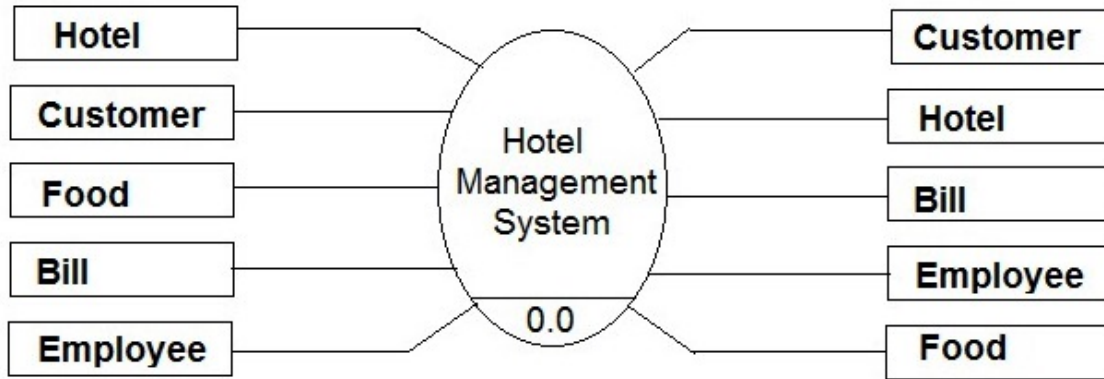

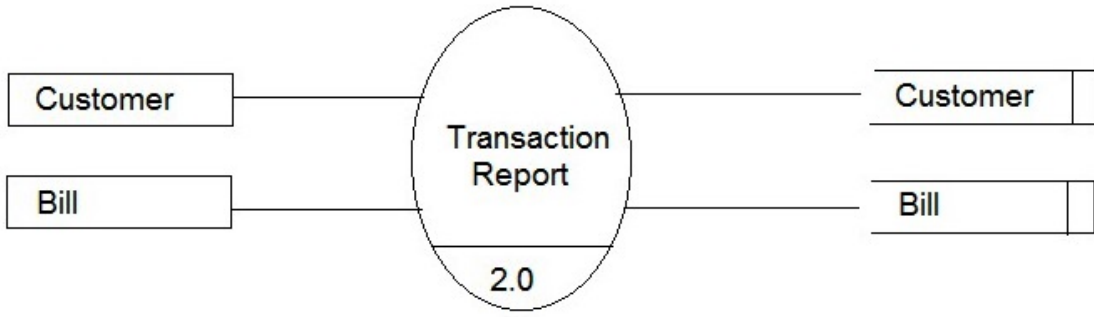

FILE DESIGN

1) Customer

| SR No | Field Name | Datatype | Constraints |
|-------|------------|----------|-------------|
| 1 | Id | Number | Primary key |
| 2 | Cname | Text | - |
| 3 | Cadd | Text | - |
| 4 | Ccont | Text | - |
| 5 | Cemail | Text | - |

2)Employee

| SR No | Field Name | Datatype | Constraints |
|-------|------------|----------|-------------|
| 1 | Id | Text | Primary key |
| 2 | ename | Text | - |
| 3 | Eadd | Text | - |
| 4 | Econt | Text | - |
| 5 | edesig | Text | - |

3)Food

| SR No | Field Name | Datatype | Constraints |
|-------|------------|----------|-------------|
| 1 | Id | Number | Primary key |
| 2 | Ftyoe | Text | - |
| 3 | Fname | Text | - |
| 4 | rate | Number | - |

4)Hotel

| SR No | Field Name | Datatype | Constraints |
|-------|------------|----------|-------------|
| 1 | Id | Number | Primary key |
| 2 | hname | Text | - |
| 3 | Had | Text | - |
| 4 | hcont | Text | - |
| 5 | hemail | text | - |

5)CustomerBill

| SR No | Field Name | Datatype | Constraints |
|-------|------------|-----------|-------------|
| 1 | Id | Number | Primary key |
| 2 | bdate | Date/Time | - |
| 3 | btime | Date/Time | - |
| 4 | Cid | number | Foreign Key |
| 5 | Prod1 | Text | - |
| 6 | Qty1 | Number | - |
| 7 | pric1 | Number | - |
| 8 | Tot1 | Number | - |
| 9 | Prod2 | Text | - |
| 10 | Qty2 | Number | - |
| 11 | Pric2 | Number | - |
| 12 | Tot2 | Number | - |
| 13 | Prod3 | Text | - |
| 14 | Qty3 | Number | - |
| 15 | Pric3 | Number | - |
| 16 | Tot3 | Number | - |
| 17 | totalamt | Number | - |

Form Design

Login

The screenshot displays the Microsoft Visual Basic IDE for a project named "KDsKitchen". The main window shows the code for the "frmEmployee" form. A "Login" dialog box is overlaid on the code, featuring a blue header, a lock icon, and two input fields: "User Name" with the text "admin" and "Password" with three asterisks. "Login" and "Cancel" buttons are at the bottom right of the dialog.

```
MsgBox "Saved...", vbInformation

End If
flag = 0
End Sub

Private Sub Command3_Click()
f = 2
If f = 2 Then
rs.Fields(1) = txtname.Text
rs.Fields(2) = txtadd.Text
rs.Fields(3) = txtcon.Text
rs.Fields(4) = cmbdes.Text
rs.Update
MsgBox "Updated...", vbInformation
End If
flag = 0
End Sub

Private Sub Command4_Click()
Unload Me
End Sub

Private Sub Form_Load()
cn.ConnectionString = "Provider=Microsoft.Jet.OLEDB.4.0;Data Source=D:\KD's Kitchen\KDDb.mdb"
cn.Open
rs.Open "select * from Employee", cn, adOpenDynamic, adLockOptimistic
txtid.Text = rs.Fields(0)
txtname.Text = rs.Fields(1)
txtadd.Text = rs.Fields(2)
```

The Project Explorer on the right shows the "KDsKitchen (KDsKitchen.vbp)" project structure, including a "Forms" folder with files like frmAbout, frmBillDetails, frmCustomer, frmEmployee, frmFodd, frmHotel, frmLogin, frmSearchCust, frmSplash, and MDIForm1, and a "Designers" folder with DataEnvironment1, DataReport1, DataReport2, and DataReport3.

The Windows taskbar at the bottom shows the system tray with the date and time: 6:56 PM, 02/04/2021.

MDI

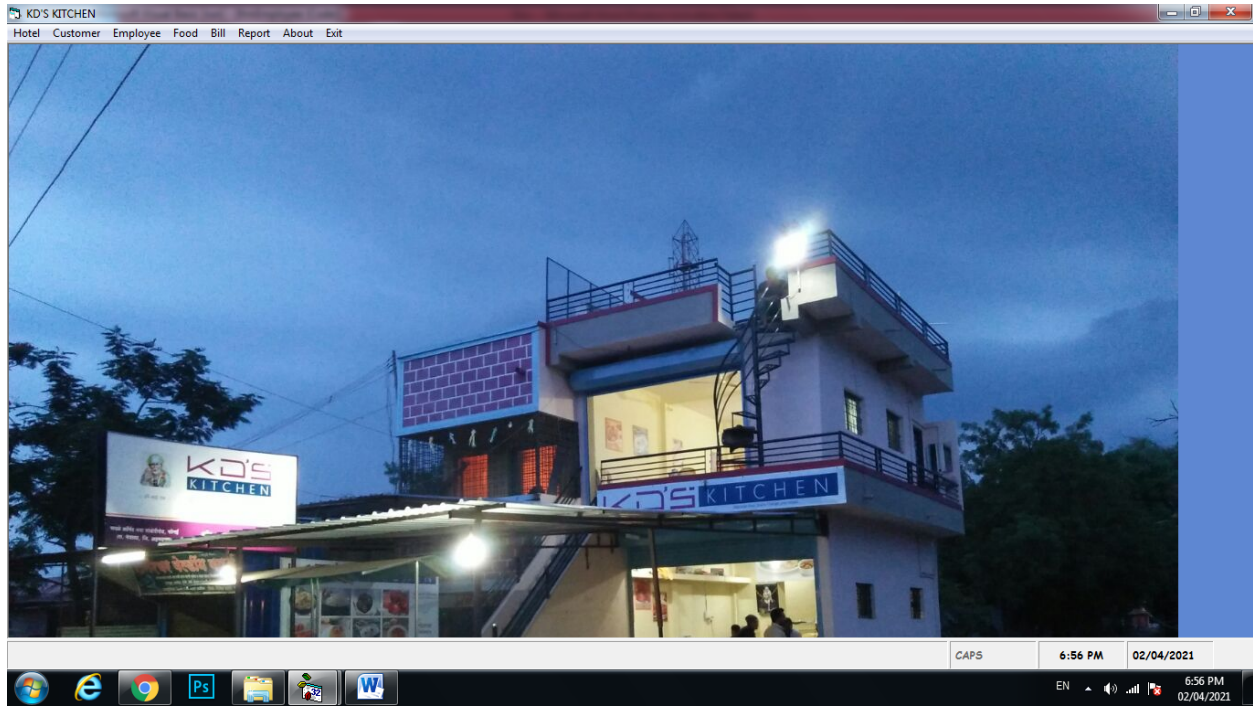

Hotel

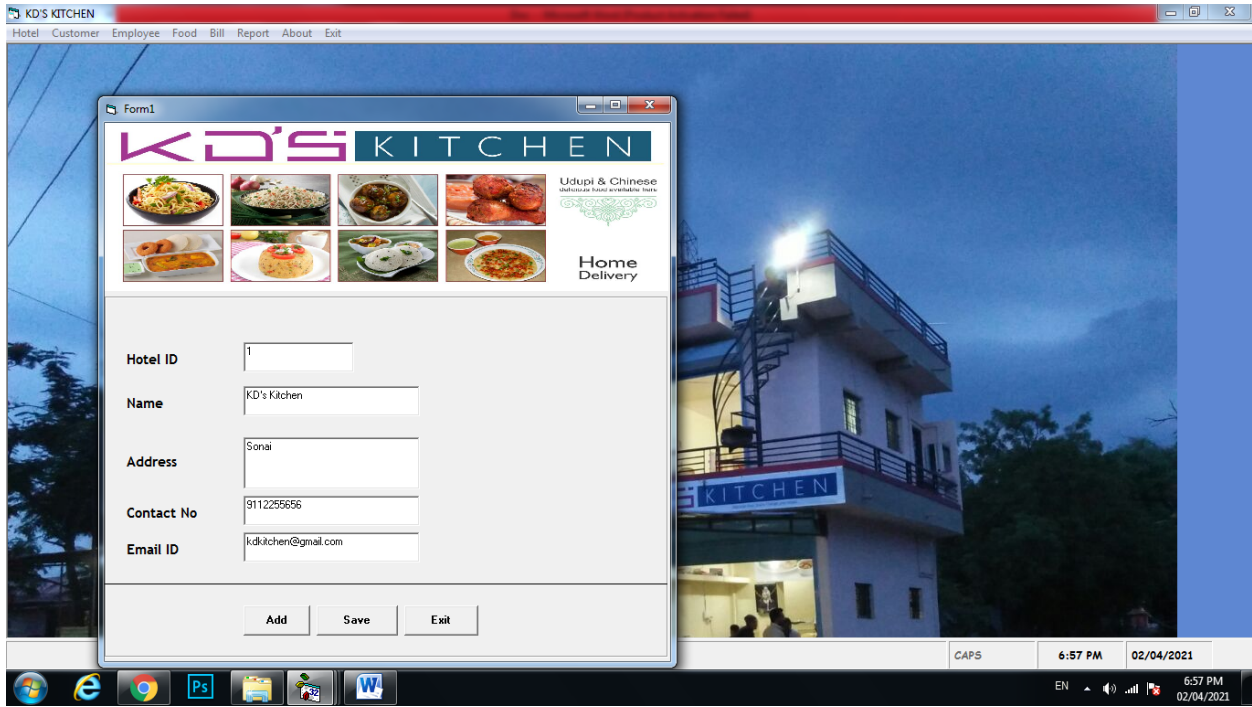

Customer

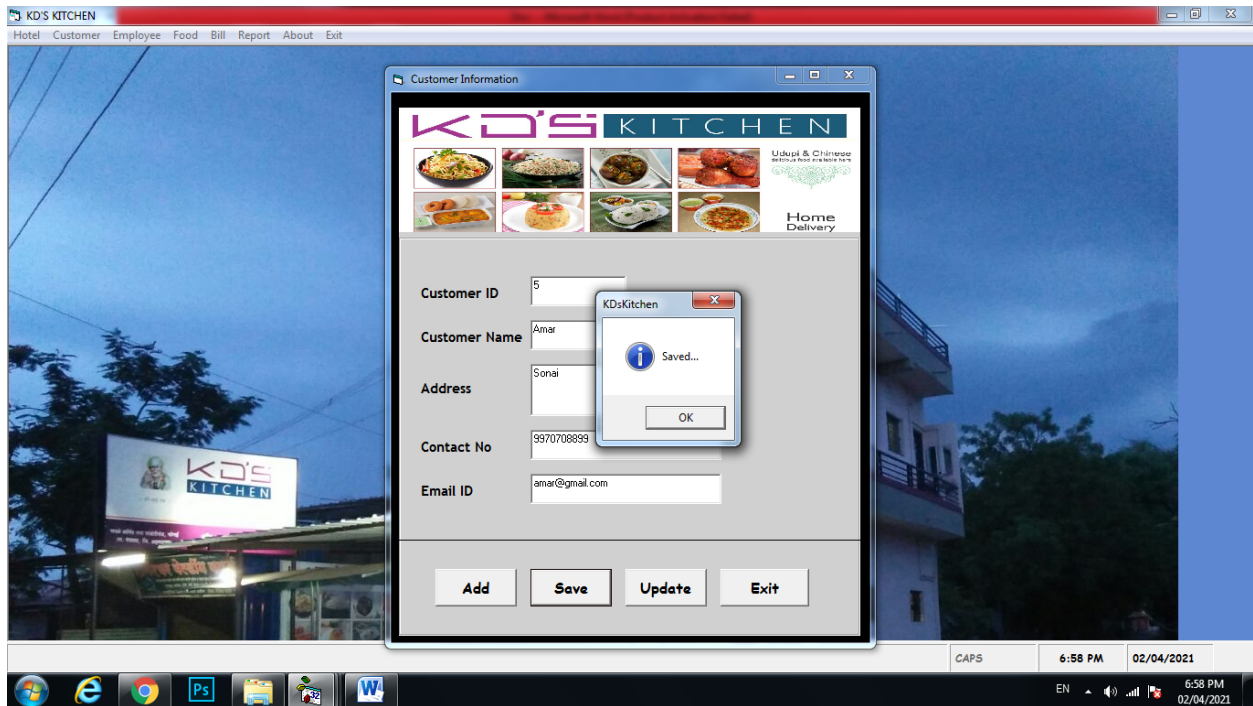

Employee

The screenshot displays a web browser window titled "KD'S KITCHEN" with a menu bar containing "Hotel", "Customer", "Employee", "Food", "Bill", "Report", "About", and "Exit". The main content area features a background image of the restaurant's exterior at dusk. A central "Form1" window is open, displaying the "KD'S KITCHEN" logo and a grid of food images. Below the images, the form includes the following fields:

- Employee ID: 6
- Employee Name: Vijay
- Address: Rahuri
- Contact No: 7887996633
- Designation: Manager (dropdown menu)

At the bottom of the form are buttons for "Add", "Save", "Update", and "Exit". A small "KD'SKitchen" dialog box with an information icon and the text "Saved..." is overlaid on the form, with an "OK" button.

The Windows taskbar at the bottom shows the system tray with "CAPS", "7:00 PM", and "02/04/2021". The taskbar icons include Windows, Edge, Chrome, Photoshop, File Explorer, and Word.

Food

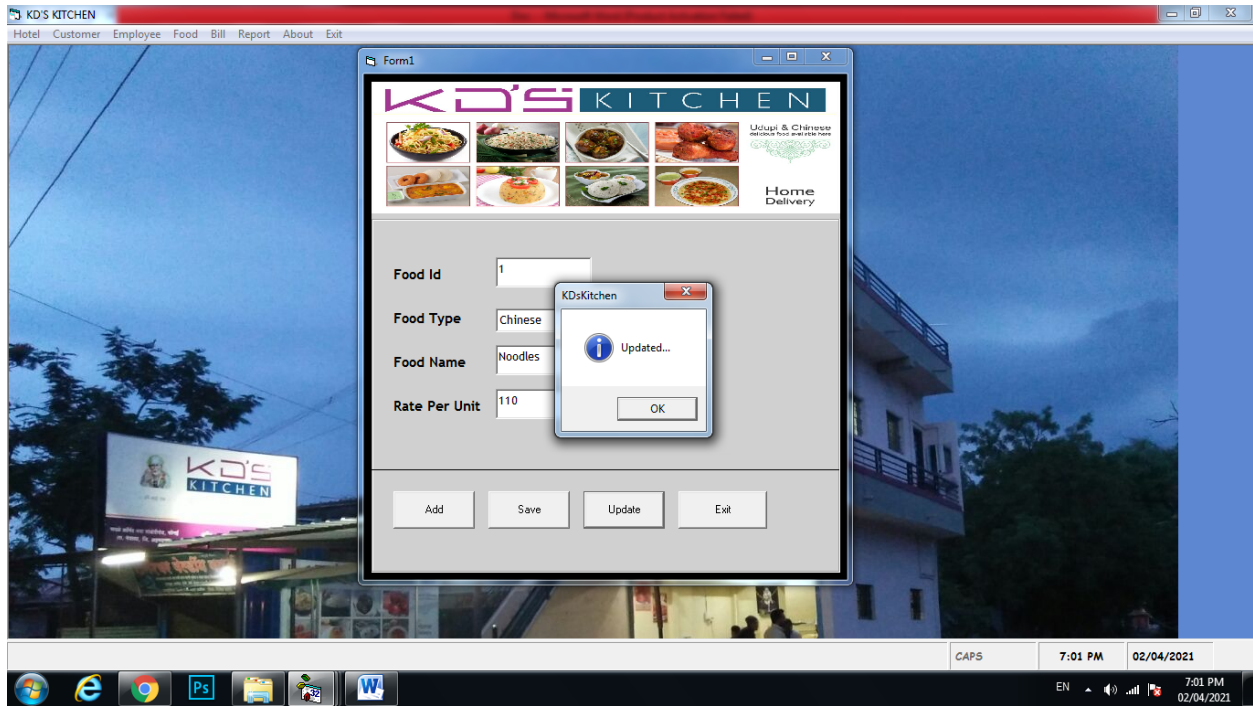

Bill

KD'S KITCHEN
Udupi & Chinese
Cuisine is here in a single place
Home Delivery

Hotel Customer Employee Food Bill Report About Exit

Form1

Bill ID: 7
Customer Name: Amar

5/10/2021 7:03:10 PM

Food Details

| Name | Quantity | Price | Total |
|---------------|----------|-------|------------|
| Hakka Noodles | 1 | 130 | 130 |
| Veg Pulao | 1 | 90 | 90 |
| Jeera Rice | 1 | 70 | 70 |
| Total | | | 290 |

Buttons: Add, Save, Update, Print, Exit

KDsKitchen Saved... OK

Taskbar: CAPS, 7:03 PM, 02/04/2021, EN, 7:03 PM, 02/04/2021

Reports

Employee Details

The screenshot shows a web browser window titled 'KD'S KITCHEN' with a menu bar containing 'Hotel', 'Customer', and 'Employee'. A report window titled 'DataReport1' is open, displaying the following content:

Employee Details Friday, April 02, 2021 19:03

| Emp ID | Name | Address | Contact | Designation |
|--------|----------|------------|-----------|-------------|
| 1 | Prasad | Sonai | 919189891 | Manager |
| 2 | Sagar | Sonai | 989056789 | Cook |
| 3 | Anil K | Ahmednagar | 942234902 | Cook |
| 4 | Dipak | Ahmednagar | 904900125 | Cook |
| 5 | Sharad P | Sonai | 775690872 | Walter |
| 6 | Vjay | Rahuri | 788796663 | Manager |

The report window also shows a page navigation bar at the bottom with 'Pages: 1' and a zoom level of '100%'. The system tray at the bottom of the screen displays 'CAPS', '7:03 PM', and '02/04/2021'.

Food Details

Food Details

Friday, April 02, 2021
19:04

| Food ID | Food Type | Food Name | Rate |
|---------|-----------|-------------------|------|
| 1 | Chinese | Noodles | 110 |
| 2 | Chinese | Hukka Noodles | 130 |
| 3 | Chinese | Schezwan Noodles | 90 |
| 4 | Rice | Veg Pulao | 90 |
| 5 | Rice | Jeera Rice | 70 |
| 6 | Rice | Paneer Fried Rice | 90 |
| 7 | Rice | Kashmiri Pulao | 80 |
| 8 | Snacks | Medu Vada | 30 |
| 9 | Snacks | Special Vada | 35 |

Pages: 1

CAPS 7:04 PM 02/04/2021

EN 7:04 PM 02/04/2021

Customer Details

Bill Details

Friday, April 02, 2021
19:05

| Bill ID | Date | Name | Food | Price | Food | Price | Food | Price | Total |
|---------|------------|---------|--------|-------|----------|-------|---------|-------|-------|
| 1 | 06/10/2021 | Arnav | Noodle | 120 | Veg | 90 | Jeera | 70 | 280 |
| 2 | 08/10/2021 | Santosh | Schezw | 90 | Kashmiri | 80 | Veg | 90 | 450 |
| 3 | 14/10/2017 | Rahul | Medu | 30 | Uthappa | 70 | Jeera | 70 | 240 |
| 4 | 14/10/2017 | Rahul | Kashmi | 80 | Veg | 90 | Jeera | 70 | 310 |
| 5 | 15/10/2017 | Ashok | Paneer | 90 | Masala | 70 | Special | 35 | 230 |
| 6 | 23/10/2017 | Rahul | Jeera | 70 | Veg | 90 | Jeera | 70 | 300 |
| 7 | 06/10/2021 | Amar | Hakka | 130 | Veg | 90 | Jeera | 70 | 290 |

Pages: 1

CAPS 7:05 PM 02/04/2021

EN 7:05 PM 02/04/2021

LIMITATIONS:-

- Time consuming.
- Large amounts of records are to be kept are difficult to store safely.
- Paper work is very tedious, report production is very slow.
- More man power required .due to all this reasons we are moving for proposed system.

Conclusion

1. The System is easy to understand and operate and it is also user friendly.
2. The user can get all the information.
3. The user wants as it can help himself.
4. The user is guided through with all the links and information.

Future Enhancement

The system can be made more users friendly and reliable by implementing some advantages in our system by providing following facilities:

- The system can be extended in multi-user system in future.
- Also various other reports as per requirements can be added on user request in future.
- Provision of Bills receipt for Customer in printed format.
- Provision of online help for user.

Reference

1) The complete Reference VB6

-Noel Jerke

2) ADO Programming in Visual Basic 6

-Steven Holzner